

CD4 series

CD4 Series with linear image sensor and electronic shutter provides accurate measurement.

- Laser displacement sensor features easy setup and operation.
- High accuracy of $0.1\ \mu\text{m}$ resolution and $\pm 0.1\%$ F.S. linearity. (Specular Type)
- Specular type (CD4L-25) optics that are ideal for glass sensing.



SENSORHEAD VARIATION

LS

CD5

CD4

CD33

CD3

CD22

CD1

UQ1

〈For general use〉

Regular
type

CD4-30 (IEC Class 2 「FDA CLASS II」 Type)

CD4-30-3R (High power Class 3R Type)

Short distance

Tire inspection

Measurement range : 30 ±5mm

Resolution : 1 μm

Linearity : ±0.1% F.S.

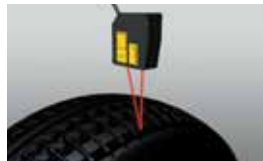
Regular
type

CD4-85 (IEC Class 2 「FDA CLASS II」 Type)

CD4-85-3R (High power Class 3R Type)

Middle distance

Checking clear package of IC mounted on PCB

Measurement range : 85 ±20mm

Resolution : 3 μm

Linearity : ±0.1% F.S.

Regular
type

CD4-350 (IEC Class 2 「FDA CLASS II」 Type)

CD4-350-3R (High power Class 3R Type)

Long distance

Monitoring the die cast

Measurement range : 350 ±100mm

Resolution : 40 μm

Linearity : ±0.1% F.S.



〈For glass material〉

Specular
type

CD4L-25 (IEC Class 1 「FDA CLASS II」 Type)

Specular type

Monitoring warping sagging of glass plate

Measurement range : 25 ±1mm

Resolution : 0.1 μm

Linearity : ±0.1% F.S.



CD4 SENSOR HEADS

CD4 Series laser displacement sensor with linear image sensor and electronic shutter provides accurate measurement.

Measuring range

<General use>

CD4-30
CD4-30-3R Short range : 30 ±5mm

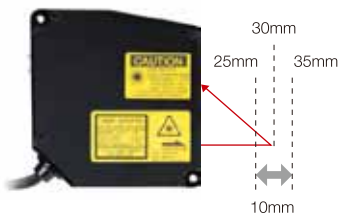

<Glass material>

CD4L-25 Specular type : 25 ±1mm
The optical path is designed to project the correct angle for the detection of specular reflections from transparent objects.



CD4-85
CD4-85-3R Middle range : 85 ±20mm

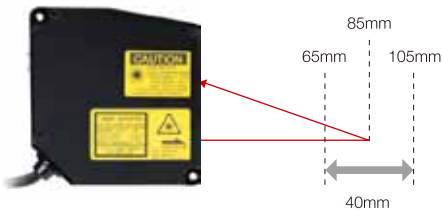

CD4-350
CD4-350-3R Long range : 350 ±100mm

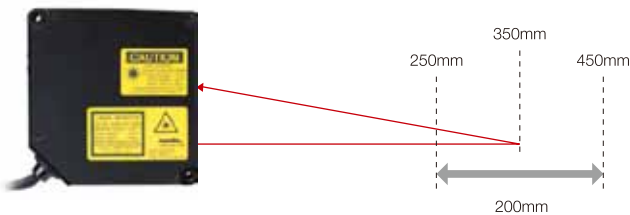

Class 2 (IEC/JIS) CLASS II (FDA) laser product

CD4-30

CD4-85

CD4-350

High power type (models with “-3R”) has class 3 laser



Class 3R - High power types

CD4-30-3R

CD4-85-3R

CD4-350-3R

For matte black objects or any application that requires a higher power laser, there are models of the CD4 series available which use a Class 3R light source.



Class 1 (IEC/JIS) CLASS II (FDA) laser product

CD4L-25

CD4L-25 is registered to CDRH. (Center of devices and radiological health)



High speed sampling rate

The CD4 Displacement sensor has a 100μsec. sampling rate and high density linear image detector.

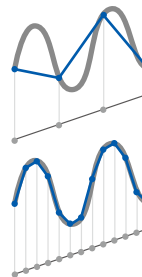

Conventional displacement sensor with slow response.

CD4 Series sensors, high speed sampling rate improves overall accuracy.

IP67 Environmental rating

The sensing heads of the CD4 series have an IP67 rating for use in applications where they may be exposed to water.



CD4 CONTROLLERS

The CD4 controller is easy to operate with simple pushbutton setup and an LCD display to verify / change the settings.

LCD Display

The CD4A-N(or P) controller has a built-in color display that indicates multiple data values on the same screen.

Distance values from both heads, calculated value, output status, bank number, etc. are displayed on the normal run screen.



Light intensity monitor (For CD4L-25 only)

For stable measurement and improved accuracy the light intensity needs to be adjusted to the optimum setting.

With the built-in monitor the status of the level can be verified.

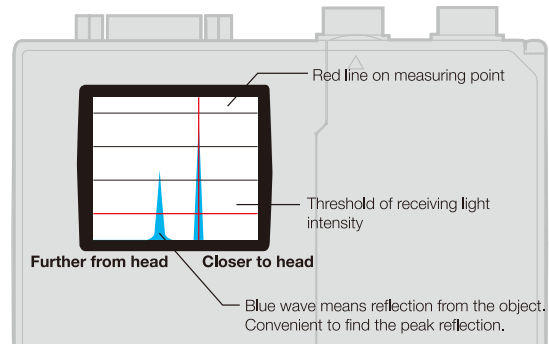

Ten formulas of calculation

A	Sensor head A
B	Sensor head B
A+B	Adding of A and B
A-B	Gap between A and B
-A-B	Reverse of A+B
K-A-B	K = distance between sensors. Good for measuring thickness.
K+A+B	K = Offset value
K+A-B	K = Offset value
K+A	Offset the sensor A. K = Offset value
K+B	Offset the sensor B. K = Offset value

8 Banks selections

Bank No.	Bank 2 input	Bank 1 input	Bank 0 input
0	OFF	OFF	OFF
1	OFF	OFF	ON
2	OFF	ON	OFF
3	OFF	ON	ON
4	ON	OFF	OFF
5	ON	OFF	ON
6	ON	ON	OFF
7	ON	ON	ON

Electronic shutter

The microcomputer in the CD4 controller will automatically control the shutter speed depending upon the reflectance of the target.

This will select the best light intensity level for accurate measurement and will help to minimize the error (AUTO Sensitivity Mode).

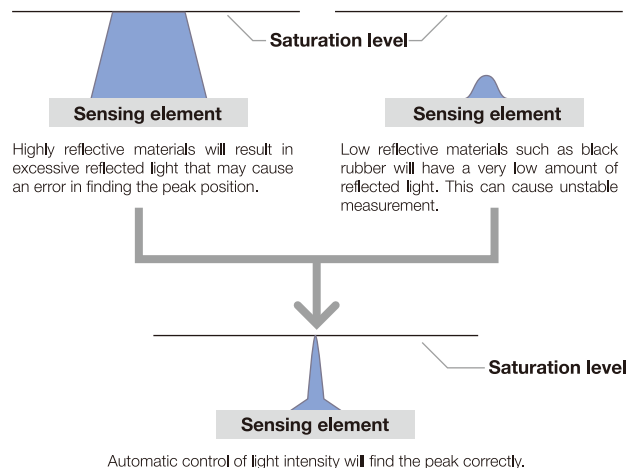

RS-232C Communications

By connecting the CD4 controller to a PC, the following operations can be performed from the PC via RS232C.

- Writing and reading out the setting value
- Reading out the measurement value
- Reading out the control output status
- Operating the control input
- Data buffer function

Communication method	RS-232C
Transmission type	Asynchronous
Baud rate	9600/19200/38400/115200 bps
Transmission code	ASCII
Data length	7/8 bit
Stop bit length	1 bit
Parity check	Nil/Even number/Odd number
Data classification	STX·ETX

The underlined values are the factory default settings.

Adjust the communication settings of the PC and the CD4 using the values in the above table. The settings of the CD4 controller can be accessed in screen number 14 (RS232C).

Low / High pass filters

High / Low pass filters are built into the CD4 controller. A low pass filter will help to reduce any sudden changes in the measurement while the high pass filter will eliminate slow gradual changes.

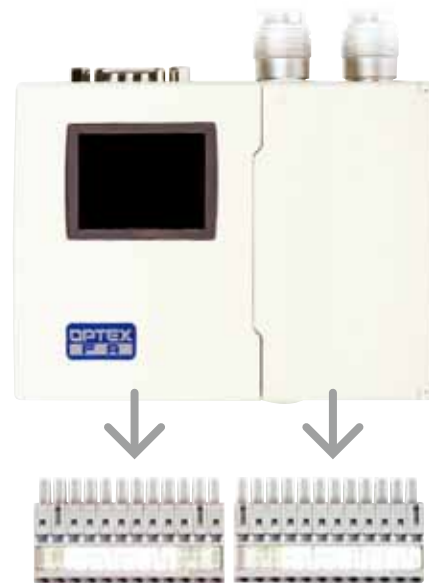

Easy disconnection of QD type.

5 Independent outputs are available

This is convenient for sorting items according to size. Each of the 5 comparator outputs can be set independently, all outputs have a high and low threshold limit.

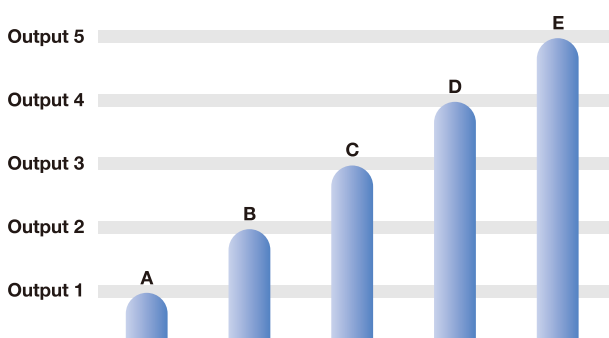

Two sensing heads can be controlled

Therefore it computes for the purpose of measuring thickness, width, etc.

Independent measurement from each head is possible as well. Any combination of measurement heads (30, 85, 350) can be used together.



Dimensions

CD4 series sensor head

Model No. : CD4-30/-30-3R/-85/-85-3R

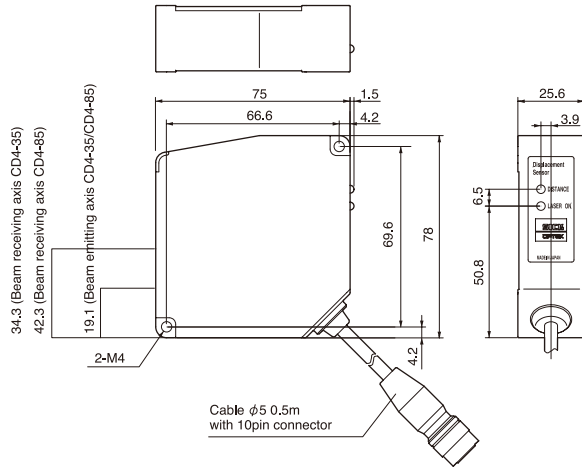

Model No. : CD4-350/-350-3R

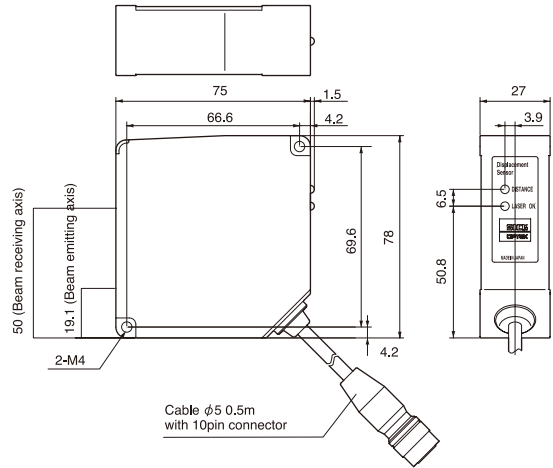

CD4L-25 Sensor head

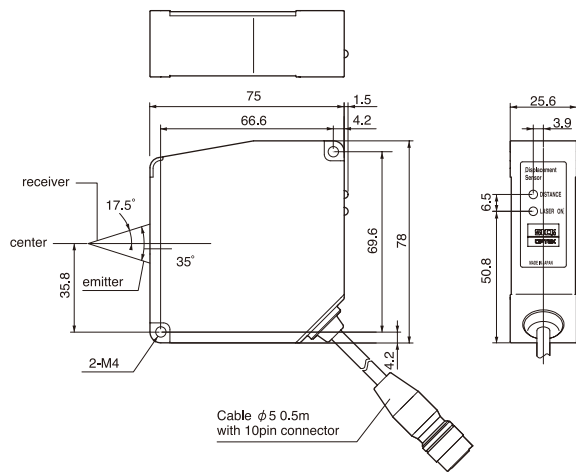

Cable

Model No. : CD4CN-S-ROBOT

: Extension 2m cable to connect the sensor head

Model No. : CD4CN-5S-ROBOT

: Extension 5m cable to connect the sensor head



Controller

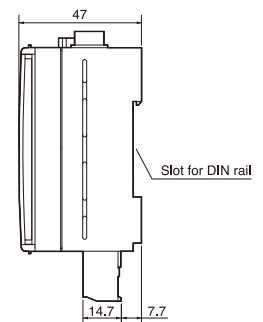
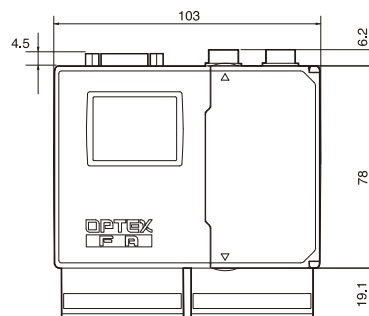
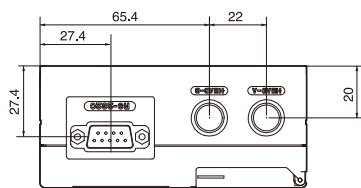

(mm)

Specifications

CD4 series

Model	IEC Class 1 (FDA CLASS II) Type	CD4-30	CD4-85	CD4-350
	High power Class 3R Type	CD4-30-3R	CD4-85-3R	CD4-350-3R
Measurement range		30 ±5mm	85 ±20mm	350 ±100mm
Light source	(Regular type)	Class 2 (IEC / JIS) CLASS II (FDA) Red laser diode , 650nm, max 1m W		
	(High power type)	Class 3R (IEC / JIS) CLASS III a (FDA) Red laser diode, 650nm, max 5mW		
Spot size (*1)		30×100μm	70×290μm	300×700μm
Linearity (*2)		±0.1% F.S.		
Resolution (*3)		1μm	3μm	40μm
Supply voltage		Supplied by CD4A-N / P controller		
Temp drift		±0.01% F.S. / °C		
Laser emission indicator		Green = Laser emission		
Measurement indicator		Red = In range, closer than center 5% of measurement range (0 to 45%) Orange = Within ±5% of the center of the measuring range Green = In range, farther than center 5% of measurement range (55 to 100%) Red / Green alternating = Out of measuring range		
Protection category		IP67		
Operation temp / humidity		-10 to +45 °C (14 to 113 °F), 35 to 85% RH		
Storage temp / humidity		-20 to +60 °C (-4 to 140 °F), 35 to 85% RH		
Environmental illuminance		Incandescent lamp = Max 3,000 lux		
Vibration resistance		10 to 55 Hz double amplitude 1.5mm for XYZ		
Shock resistance		50G (500m/s ²)		
Cable		50cm (19.7 inch) cable		
Cable extension		CD4CN-S-ROBOT (2m, 78 inch), CD4CN-5S-ROBOT (5m, 197 inch)		
Material		Aluminum diecast		

*1 Defined with center strength 1/e² (13.5%). There may be leak light other than the spot size. The sensor may be affected when there is a highly reflective object close to the detection area.

*2 256 times in average (using the special amplifier), object: White ceramic. The value is subject to objects.

*3 The typical value in the conditions of 256 times in average (using the special amplifier), object: White ceramic, distance range: Middle. The value is subject to objects.

CD4L-25

Model	CD4L-25
Measurement range	25 ±1mm
Light source	Class 1 (IEC / JIS) CLASS II (FDA) Laser, 650nm, max 390 μW
Spot size (*1)	25×35 μm
Linearity (*2)	± 0.1% F.S.
Resolution (*3)	0.1 μm
Supply voltage	Supplied by CD4A-LN/LP controller
Temp drift	±0.01% F.S. / °C
Laser emission indicator	Green = Laser emission
Measurement indicator	Red = In range, closer than center 5% of measurement range (0 to 45%) Orange = Within ±5% of the center of the measuring range Green = In range, farther than center 5% of measurement range (55 to 100%) Red / Green alternating = Out of measuring range
Protection category	IP67
Operation temp / humidity	-10 to +45 °C (14 to 113 °F), 35 to 85% RH
Storage temp / humidity	-20 to +60 °C (-4 to 140 °F), 35 to 85% RH
Environmental illuminance	Incandescent lamp = Max 3,000 lux
Vibration resistance	10 to 55 Hz double amplitude 1.5mm for XYZ
Shock resistance	50G (500m/s ²)
Cable	50cm (19.7 inch) cable
Cable extension	CD4CN-S-ROBOT (2m, 78 inch), CD4CN-5S-ROBOT (5m, 197 inch)
Material	Aluminum diecast

*1 Defined with center strength 1/e² (13.5%). There may be leak light other than the spot size. The sensor may be affected when there is a highly reflective object close to the detection area.

*2 256 times in average (using the special amplifier), object: evaporated aluminum mirror. The value is subject to objects.

*3 The typical value in the conditions of 256 times in average (using the special amplifier), object: White ceramic, distance range: Middle. The value is subject to objects.

Controller

Model		CD4A-N / -LN (NPN output type)	CD4A-P / -LP (PNP output type)
Number of heads		Max.2 pcs	
Sampling period		100 μ s	
Supply voltage		12 - 24VDC \pm 10%	
Power consumption		270mA / 24VDC (When connected with 2 sensor heads. Including analog current output)	
Temp drift		\pm 0.01% F.S. / $^{\circ}$ C	
Analog output	ANG (V) [A] [B]	Voltage output \pm 5V / F.S. (Output impedance 100 Ω , resolution 1mV)	
	ANG (mA) [A] [B]	Current output 4 to 20mA / F.S. (Load impedance 300 Ω , resolution 1.5 μ A)	
Alarm output	ALM A,ALM B	NPN open collector	PNP open collector
		Max. 100mA / 24VDC (residual voltage Max. 1.8V) Turns ON when the sensor head fails in measurement.	
Control output	JDGE 1 to 5	NPN open collector	PNP open collector
		Max. 100mA / 24VDC (residual voltage Max. 1.8V)	
		HI / LO setting and Hysteresis setting are available for each output.	
Bank input	BANK 0 to 2	ON when connected to GND	ON when connected to 12 - 24VDC
		8 banks selectable	
Hold input	HOLD A, HOLD B, HOLD RST	ON when connected to GND	ON when connected to 12 - 24VDC
		Laser off or measurement value holding (selectable in the menu)	
Zero reset input	ZERO A, ZERO B	ON when connected to GND	ON when connected to 12 - 24VDC
		Zero reset of head A measurement value / Head B measurement value / Calculation value is available.	
Optional features		Average sampling times, Filter mode (Cut-off frequency), Calculation, Hold setting, Output during alarm, Output control (Hysteresis), Analog output, Sensor head sensitivity control, Timer function, Memory function, Memory bank function, Auto zero reset	
Display type		LCD display	
Protection category		IP20	
Operation temp / humidity		-10 to +45 $^{\circ}$ C (Non-condensing) / 35 to 85% RH	
Storage temp / humidity		-20 to +60 $^{\circ}$ C / 35 to 85% RH	
Vibration resistance		10 to 55Hz, Double amplitude 1.5mm, 2h for XYZ axis	
Shock resistance		20G (196m/s 2)	
Material		Chassis: Polycarbonate, Connection terminals: Nylon 66	
Weight		240g (including connection terminals)	

Linearity (Typical example data)

CD4 series : by material

Model No. : CD4-30 / CD4-30-3R

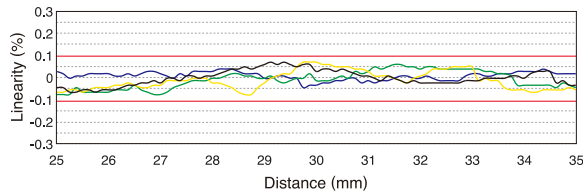

Model No. : CD4-85 / CD4-85-3R

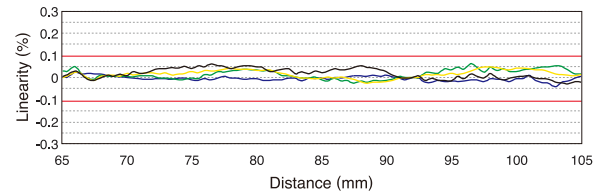

Model No. : CD4-350 / CD4-350-3R

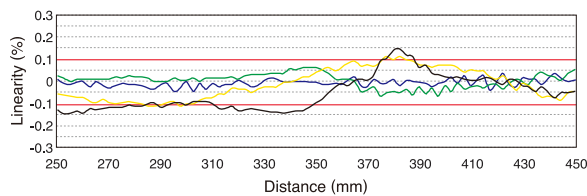

- White ceramic
- Aluminum
- Gray ceramic
- Black rubber

CD4L-25 : by angle



±0° (Typical)

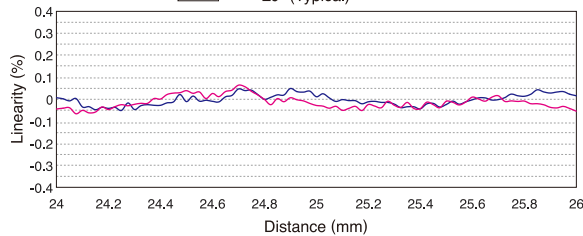

+0.2° (Typical)

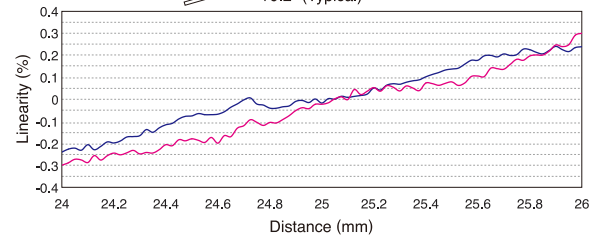

±0.2° (Typical)

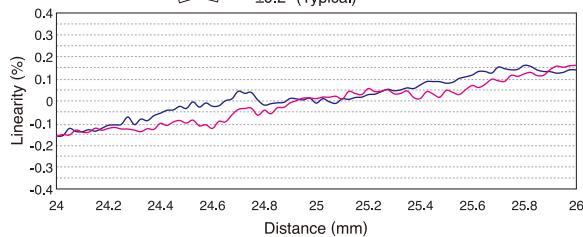

-0.2° (Typical)

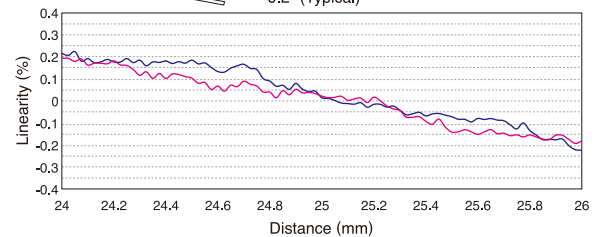

- Mirror(SENS=MIN)
- Glass(SENS=8)

LS

Spot size

CD5

CD4 series

CD4

Model No. : CD4-30 / CD4-30-3R

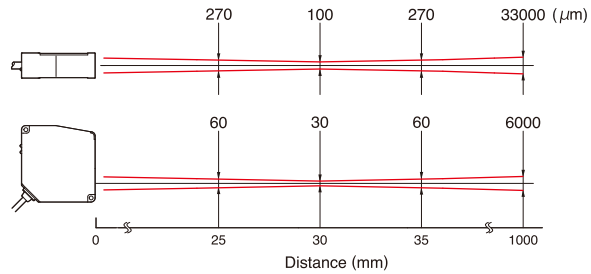

Model No. : CD4-85 / CD4-85-3R

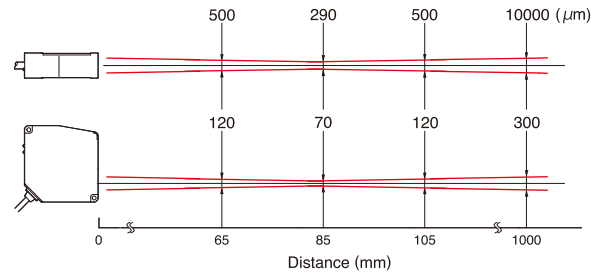

Model No. : CD4-350 / CD4-350-3R

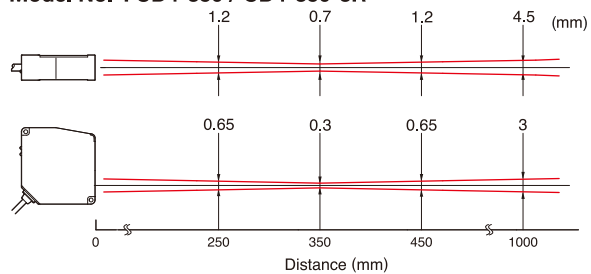

CD4L-25

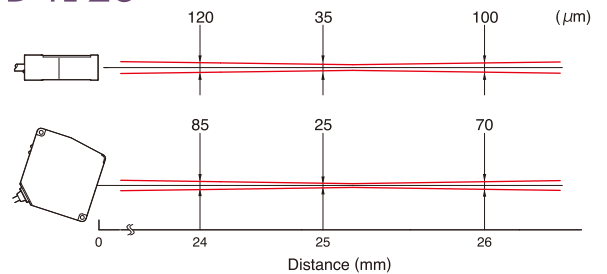

CD33

CD3

CD22

CD1

UQ1

Interference area

CD4 series

Model No. : CD4-30/CD4-30-3R

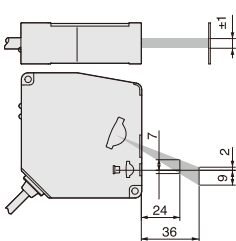

Model No. : CD4-85/CD4-85-3R

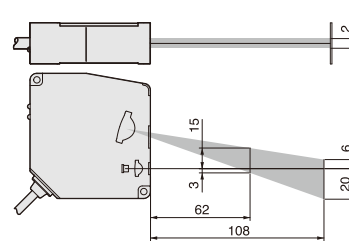

Model No. : CD4-350/CD4-350-3R

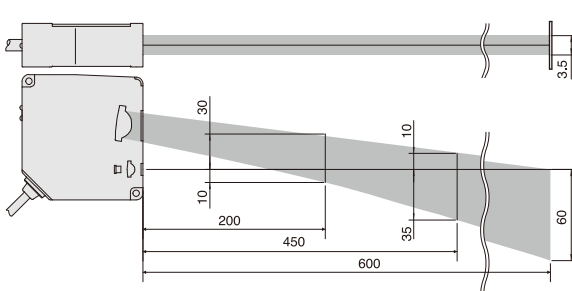

CD4L-25

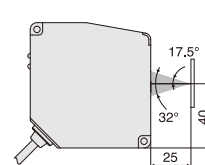

(mm)

Input / Output diagrams

NPN model bank input
Hold input
Zero reset input

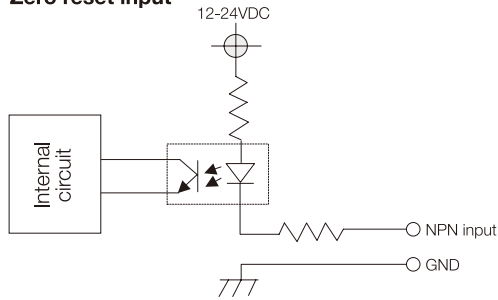

NPN model control output
Alarm output

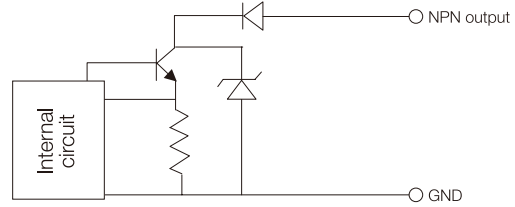

PNP model bank input
Hold input
Zero reset input

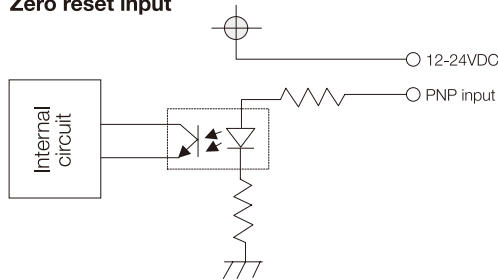

NPN model control output
Alarm output

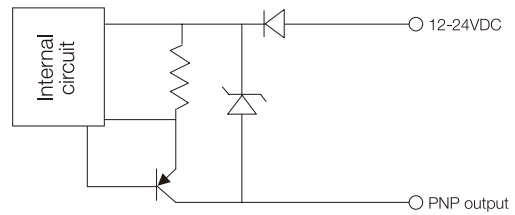

Analog output (A/B)

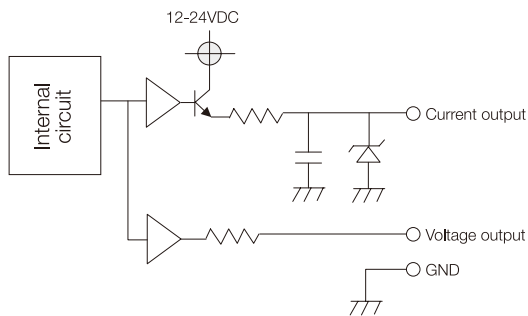

LS

CD5

CD4

CD33

CD3

CD22

CD1

UQ1